



## LM337A

Preliminary

LINEAR INTEGRATED CIRCUIT

### 1.5A, ADJUSTABLE OUTPUT, NEGATIVE VOLTAGE REGULATOR

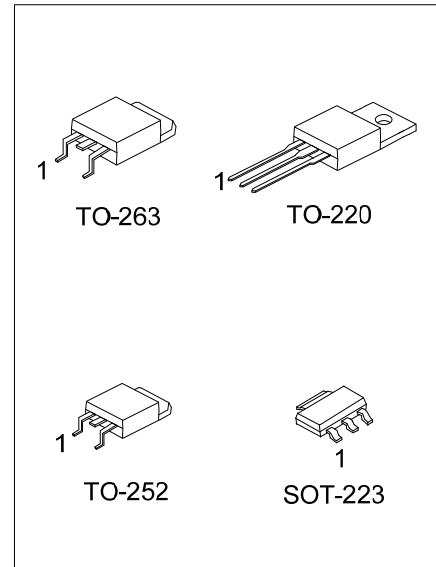

#### DESCRIPTION

The UTC **LM337A** is an adjustable 3-terminal negative voltage regulator capable of supplying in excess of 1.5A over an output voltage range of -1.25V to -37V. This voltage regulator is exceptionally easy to use and requires only two external resistors to set the output voltage. Further, it employs internal current limiting, thermal shutdown and safe area compensation, making it essentially blow-out proof.

The UTC **LM337A** serves a wide variety of applications including local, on card regulation. This device can also be used to make a programmable output regulator, or by connecting a fixed resistor between the adjustment and output, the UTC **LM337A** can be used as a precision current regulator.

#### FEATURES

- \* Output current in excess of 1.5A
- \* Output adjustable between -1.25V and -37V
- \* Internal short circuit current limiting constant with temperature
- \* Output transistor safe-area compensation

#### ORDERING INFORMATION

Ordering Number		Package	Pin Assignment			Packing
Lead Free	Halogen Free		1	2	3	
LM337AL-AA3-R	LM337AG-AA3-R	SOT-223	ADJ	I	O	Tape Reel
LM337AL-TA3-T	LM337AG-TA3-T	TO-220	ADJ	I	O	Tube
LM337AL-TN3-R	LM337AG-TN3-R	TO-252	ADJ	I	O	Tape Reel
LM337AL-TQ2-T	LM337AG-TQ2-T	TO-263	ADJ	I	O	Tube
LM337AL-TQ2-R	LM337AG-TQ2-R	TO-263	ADJ	I	O	Tape Reel

Note: Pin Assignment: I: Input O: Output

<p>LM337AG-AA3-R</p>	<p>(1) R: Tape Reel, T: Tube  (2) AA3: SOT-223, TA3: TO-220, TN3: TO-252  TQ2: TO-263  (3) G: Halogen Free and Lead Free L: Lead Free</p>
----------------------	---

### MARKING

SOT-223	TO-220 / TO-252 / TO-263
<p>LM337A L: Lead Free G: Halogen Free Date Code</p>	<p>UTC LM337A L: Lead Free G: Halogen Free Date Code Lot Code</p>

### PIN DESCRIPTION

PIN NO.	PIN NAME	DESCRIPTION
1	ADJ	Adjust pin
2	V <sub>IN</sub>	Input voltage pin for the regulator
3	V <sub>OUT</sub>	Output voltage pin for the regulator

### BLOCK DIAGRAM

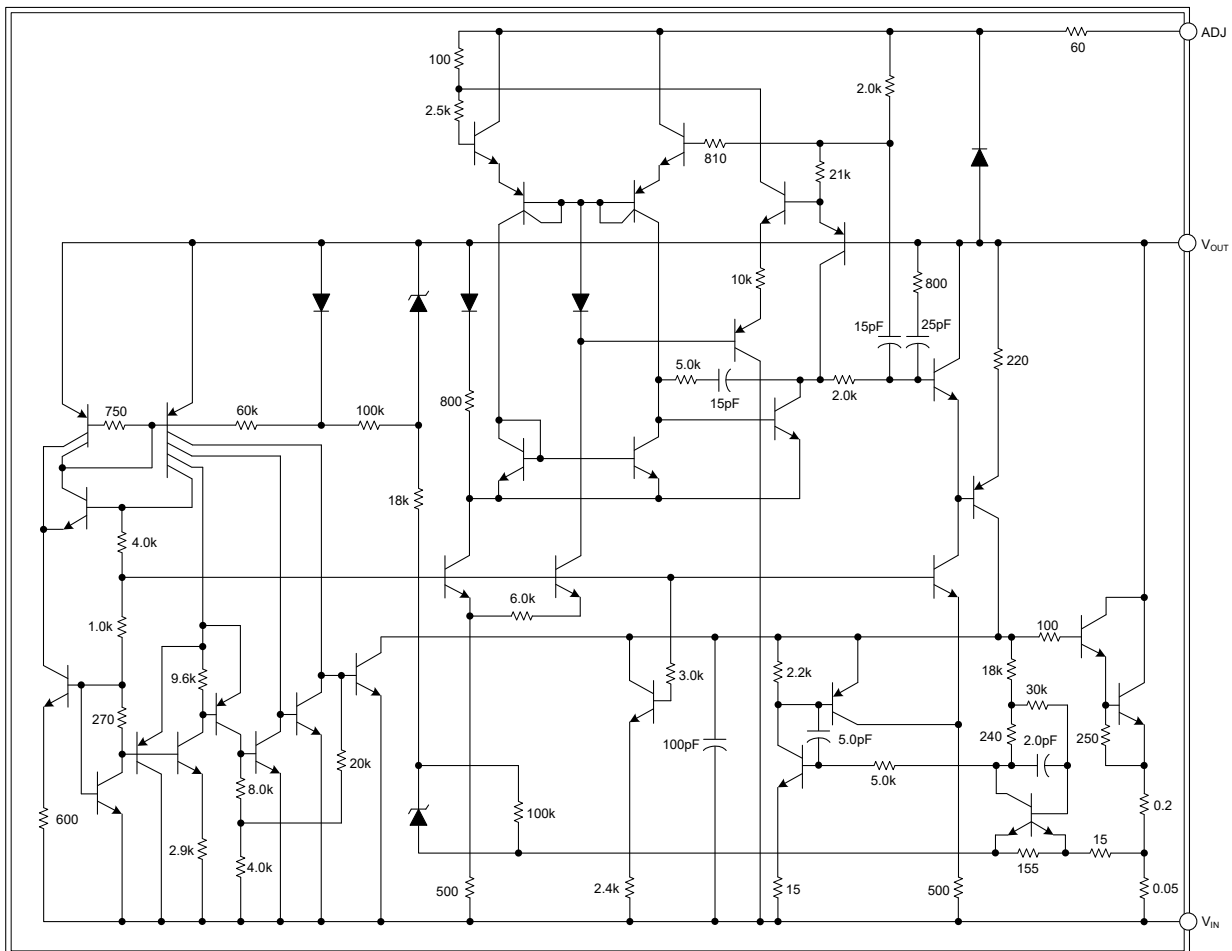

### ■ ABSOLUTE MAXIMUM RATING

PARAMETER	SYMBOL	RATINGS	UNIT
Input-Output Voltage Differential	$V_I - V_O$	40	V
Power Dissipation	$P_D$	Internally Limited	W
Operating Junction Temperature Range	$T_J$	-25 ~ +85	°C
Storage Temperature Range	$T_{STG}$	-65 ~ +150	°C

Note: Absolute maximum ratings are those values beyond which the device could be permanently damaged. Absolute maximum ratings are stress ratings only and functional device operation is not implied.

### ■ THERMAL DATA

PARAMETER	SYMBOL	RATINGS	UNIT
Junction to Ambient	SOT-223	165	°C/W
	TO-220/TO-263	65	°C/W
	TO-252	112	°C/W
Junction to Case	SOT-223	15	°C/W
	TO-220/TO-263	5	°C/W
	TO-252	12	°C/W

### ■ ELECTRICAL CHARACTERISTICS ( $|V_I - V_O| = 5.0V$ , $I_O = 0.5A$ )

PARAMETER	SYMBOL	TEST CONDITIONS	MIN	TYP	MAX	UNIT
Line Regulation (Note 1)	$\Delta V_{OUT}$	$T_A = +25^\circ C$ , $3.0V \leq  V_I - V_O  \leq 40V$		0.01	0.04	%/V
Load Regulation (Note 1)	$\Delta V_{OUT}$	$T_A = +25^\circ C$ , $10mA \leq I_O \leq I_{MAX}$	$ V_O  \leq 5.0V$		50	mV
			$ V_O  \geq 5.0V$		1.0	% $V_O$
Adjustment Pin Current	$I_{ADJ}$			65	100	$\mu A$
Adjustment Pin Current Change	$\Delta I_{ADJ}$	$2.5V \leq  V_I - V_O  \leq 40V$ , $10mA \leq I_L \leq I_{MAX}$ $P_D \leq P_{MAX}$ , $T_A = +25^\circ C$		2.0	5.0	$\mu A$
Reference Voltage	$V_{REF}$	$T_A = +25^\circ C$ , $3.0V \leq  V_I - V_O  \leq 40V$	-1.213	-1.250	-1.287	V
		$10mA \leq I_O \leq I_{MAX}$ , $P_D \leq P_{MAX}$ , $T_J = T_{LOW}$ to $T_{HIGH}$	-1.20	-1.25	-1.30	V
Line Regulation (Note 1)	$\Delta V_{OUT}$	$3.0V \leq  V_I - V_O  \leq 40V$		0.02	0.07	%/V
Load Regulation (Note 1)	$\Delta V_{OUT}$	$10mA \leq I_O \leq I_{MAX}$	$ V_O  \leq 5.0V$	20	70	mV
			$ V_O  \geq 5.0V$	0.3	1.5	% $V_O$
Minimum Load Current to Maintain Regulation	$I_{LMIN}$	$ V_I - V_O  \leq 10V$		1.5	6.0	mA
		$ V_I - V_O  \leq 40V$		2.5	10	mA
Peak Output Current	$I_{peak}$	$ V_I - V_O  \leq 15V$ , $P_D \leq P_{MAX}$		1.5	2.2	A
		$ V_I - V_O  \leq 40V$ , $P_D \leq P_{MAX}$ , $T_J = +25^\circ C$		0.15	0.4	A

Notes: 1. Load and line regulation are specified at constant junction temperature. Change in  $V_O$  because of heating effects is covered under the Thermal Regulation specification. Pulse testing with a low duty cycle is used.

2.  $C_{ADJ}$ , when used, is connected between the adjustment pin and ground.

3. Power dissipation within an IC voltage regulator produces a temperature gradient on the die, affecting individual IC components on the die. These effects can be minimized by proper integrated circuit design and layout techniques. Thermal Regulation is the effect of these temperature gradients on the output voltage and is expressed in percentage of output change per watt of power change in a specified time.

■ TYPICAL APPLICATION CIRCUIT

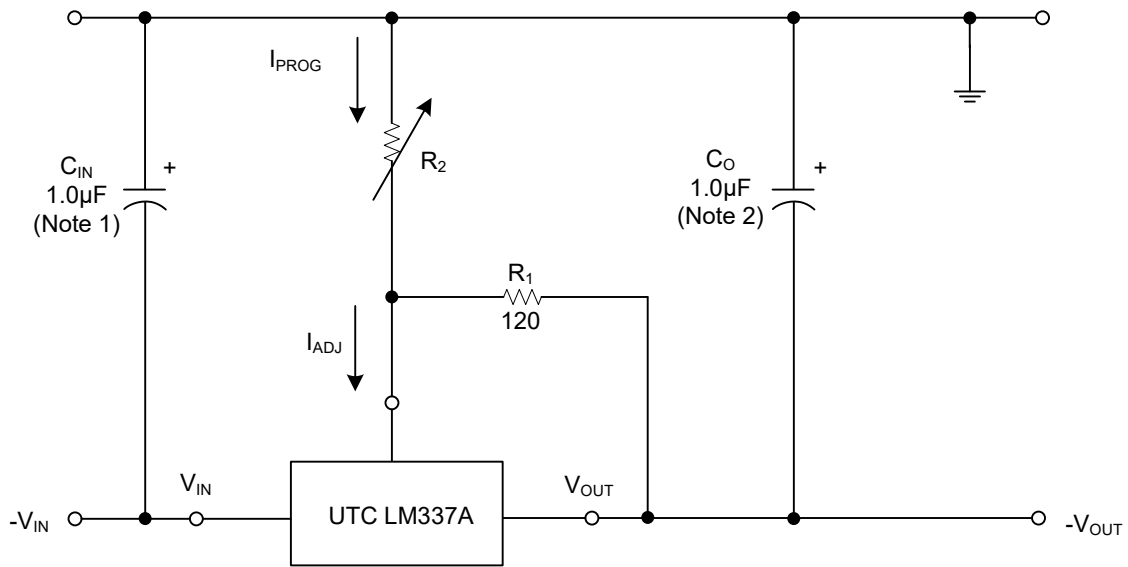

- Notes: 1.  $C_{in}$  is required if regulator is located more than 4 inches from power supply filter. A 1.0µF aluminum electrolytic is recommended.  
 2.  $C_o$  is necessary for stability. A 1.0µF aluminum electrolytic is recommended.

$$V_{OUT} = -1.25V \times \left(1 + \frac{R_2}{R_1}\right)$$

Figure 1. Standard Application

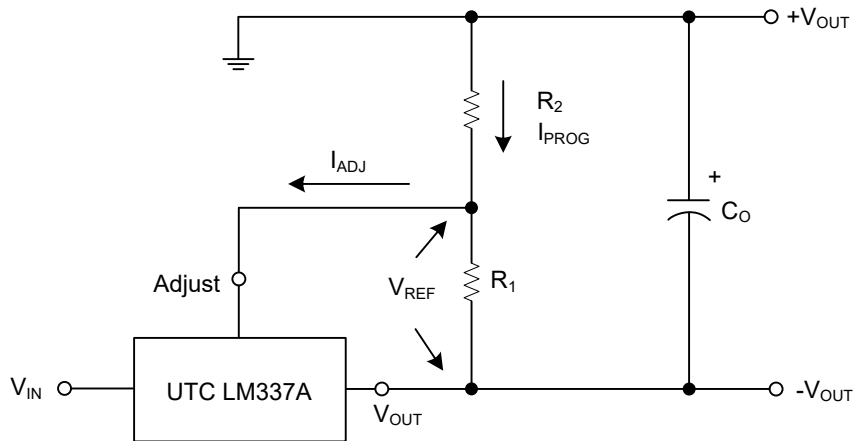

$V_{REF} = -1.25V$  Typical

Figure 2. Basic Circuit Configuration

■ TYPICAL APPLICATION CIRCUIT

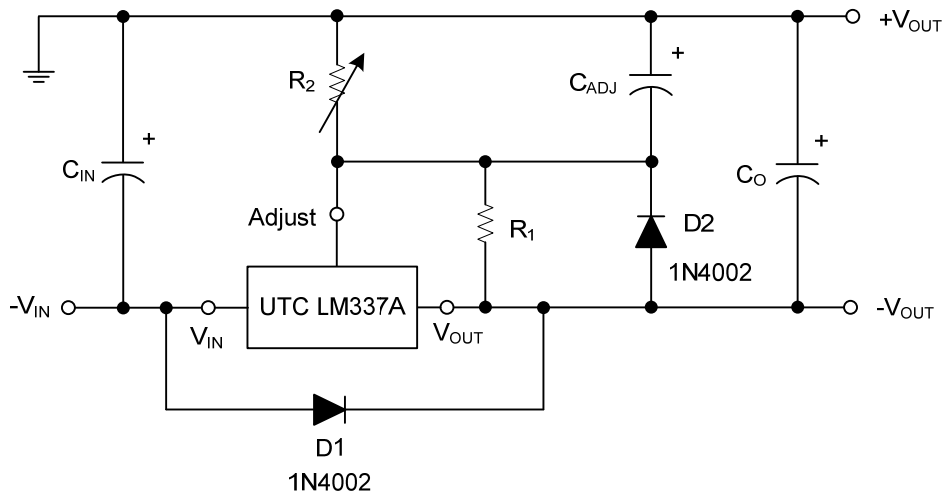

Figure 3. Voltage Regulator with Protection Diodes

UTC assumes no responsibility for equipment failures that result from using products at values that exceed, even momentarily, rated values (such as maximum ratings, operating condition ranges, or other parameters) listed in products specifications of any and all UTC products described or contained herein. UTC products are not designed for use in life support appliances, devices or systems where malfunction of these products can be reasonably expected to result in personal injury. Reproduction in whole or in part is prohibited without the prior written consent of the copyright owner. UTC reserves the right to make changes to information published in this document, including without limitation specifications and product descriptions, at any time and without notice. This document supersedes and replaces all information supplied prior to the publication hereof.