

KNSCHA[®]

全球 高端 电容器 制造商

东莞市科尼盛电子有限公司

DONGGUAN KNSCHA ELECTRONICS CO., LTD.

Specification for approval

(Customer Name) 和风科技 (香港) 有限公司

(Product Name) SMD Aluminum Electrolytic Capacitor

(Customer part number)

189RV0107

(KNSCHA number)

SMDE/C100UF/25V 6.3X5.7mm GVM

(Specifications)

(Manufacture)

Approval

(Fiction)

(Chief)

(Approval)



刘淑芬

刘军军

徐贵南

(Customer)

Approval

(Inspect)

(Chief)

(Approval)

DONG GUAN KNSCHA ELECTRONICS CO.,LTD.

No. 8th floor, A3 building, R&D center (Phase I),

Songshan Lake Intelligent Valley, Liaobu Town, Dongguan City.

TEL:0769-83698067 81035570 FAX: 0769-83861559

Email: sales@knscha.com Website: <http://www.knscha.com>



Table of specification and characteristics

Table 1

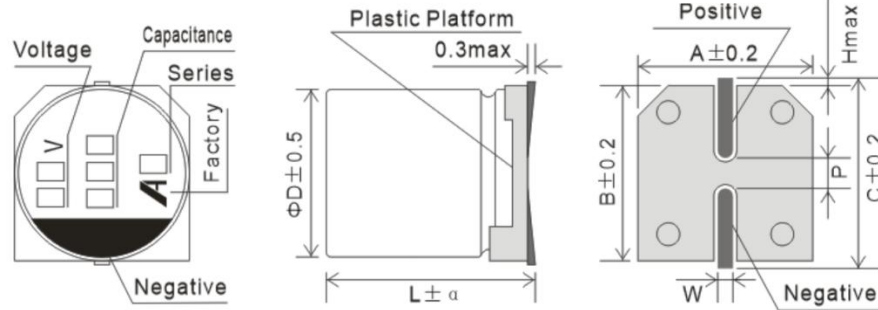

Case	$\phi 6.3 \times 5.7$
A	6.6
B	6.6
C	7.3
P	2.0
L	5.7
α	± 0.3
W	0.5~0.8
H	0.5max.

*Marking color: Black

Customer P/N	Series	Rated Capacitance (uF)	Rated Voltage (V)	Case		Capacitance Tolerance (%)	Dissipation factor (% , Max.)	Leakage Current (uA, Max.)	Surge Voltage (V)	Impedance Max. (mΩ, 20°C, 100KHz)	Max. Ripple Current (mA rms) (105°C, 100KHz)	Endurance (Hrs, at 105°C)	Vender P/N
				Diameter (mm)	Height (mm)								
	GVM	100	25	6.3	5.7	-20~+20	14.0	25	28.8	260	300	2000	189RV0107

Explanation of part numbers

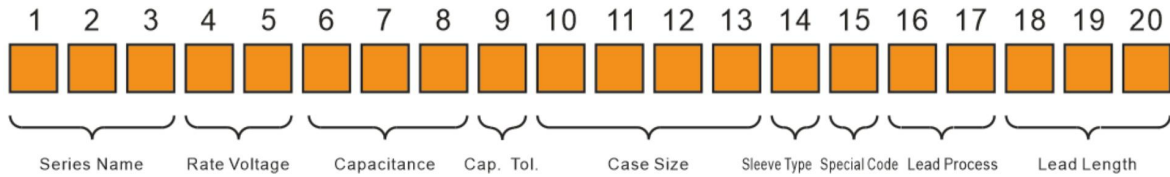

(1-3)	(4-5)		(6-8)		(9)		(10-13)		(14)	
Series	Voltage (W.V)	Code	Capacitance (mF)	Code	Cap. Tolerance (%)	Code	Size ØxL	Code	Sleeve Material	Code
GV S	4	0G	0.1	1 04	+5	J	4x5(5.4)	0405	Sleeveless	C
GV T	6.3	0J	0.22	2 24	.5		4x5.7	0406	PVC	V
GV E	10	1A	0.33	3 34	+10	K	4x7	0407	PET	E
GV Z	16	1C	0.47	4 74	-10		5x5(5.4)	0505		
GV M	25	1E	1	1 05	+15	L	5x5.7	0506		
GV L	35	1V	2.2	2 25	-15		5x7	0507		
GV U	50	1H	3.3	3 35	+20	M	5x11	0511		
GV Y	63	1J	4.7	4 75	-20		6.3x5(5.4)	0605		
GV F	80	1K	10	1 06	+30	N	6.3x5.7	0606		
GV R	100	2A	22	2 26	-30		6.3x7	0607		
GV G	125	2B	33	3 36	+20	V	6.3x7.7	0608		
GV D	160	2C	47	4 76	-10		6.3x8.7	0609		
GV P	180	2Z	68	6 86	+30	Q	8x6.5	0806		
GV T	200	2D	100	1 07	-10		8x9	0809		
GV C	220	2P	220	2 27	+50	T	8x10(10.5)	0810		
GV N	250	2E	330	3 37	-10		8x11(11.5)	0811		
GV K	315	2F	470	4 77	+50	S	8x12	0812		
GV A	330	2L	680	6 87	-20		10x10(10.5)	1010		
	350	2V	1000	1 08	+80	Z	10x12.5	1012		
	400	2G	2200	2 28	-20		10x14	1014		
	420	2Q	3300	3 38	+20	R	12.5x13.5	1213		
	450	2W	4700	4 78	-0		12.5x16	1216		
	500	2H	6800	6 88			16x16.5	1616		

(15)	
Special Code	Code
Normal	N
Wire Diameter	D
Raised gum	C

(16-17)		
Lead Process	Code	
Radial Bluk	RB	
V-Chip Type	VC	
Snap-In Type	SN	
Screw Terminal Type	ST	
Cutting	Straight Cut	CC
	Forming cut	FC
	Forming cut (ø4.5mm)	CM
	Kinked Straight Cut	SC
	Kinked Forming Cut	FS
	Banding (Right)	BR
Banding (Left)	BL	
Taping	Straight Taping	TS
	2.5mm Pitch Forming Taping	TP
	Forming Taping	TF

(18-20)	
Lead length	Code
lead length after cut is 2.8mm	028
lead length after cut is 3.0mm	030
lead length after cut is 3.2mm	032
lead length after cut is 10.0mm	100

Conformance Standard

This specification covers “GVM series” surface mount type aluminum electrolytic capacitors with non-solid electrolyte. This approval sheet consulted the institute of IEC 60384-1 and IEC 60384-4.

Operating Temperature Range

Operating temperature range is the range of ambient temperature at which the capacitor can be operated continuously at rated voltage.

Rated Voltage	Temperature
6.3 ~ 100 V _{DC}	-55 ~ +105 °C

Condition of test

Unless otherwise specified, the standard range of atmospheric conditions for making measurements and tests are as follows.

Ambient temperature: 15 °C to 35 °C

Relative humidity: 45% to 75%

Air pressure: 86Kpa to 106Kpa

If there may be doubt on the results, measurements shall be made within the following limits.

Ambient temperature: 20 ± 1 °C

Relative humidity: 63% to 67%

Air pressure: 86Kpa to 106Kpa

Construction

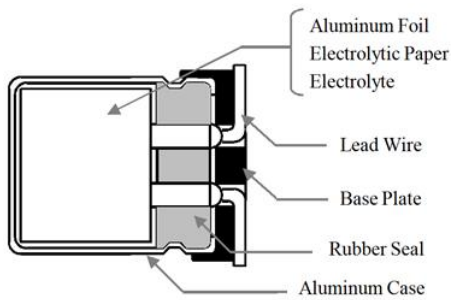

Parts Name	Materials
1 Aluminum Foil	Aluminum
2 Separator Paper	Manila Hemp
3 Electrolyte	Gamma-Butyrolactone
4 Case	Aluminum and PET
5 Rubber Seal	Butyl Rubber
6 Lead Wire	Tinned Copper-Clad Steel Wire
7 Base Plate	Thermo-plastic Resin

Ripple Current Frequency Coefficient

Frequency (Hz) \ Capacitance (uF)	50	120	1k	10k	10k up
Under 100	0.45	0.65	0.85	0.95	1.00
100 ~ 2200uF	0.50	0.70	0.90	0.95	1.00

※The endurance of capacitors is reduced with internal heating produced by ripple current at the rate of halving the lifetime with every 5 °C rise. When long life performance is required in actual use, the rms ripple current has to be reduced.

Taping Specifications:

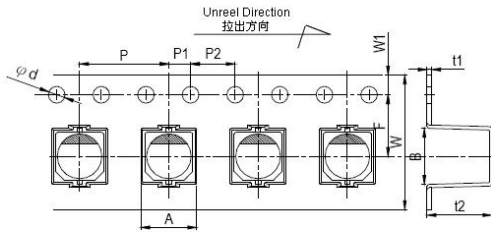

Case	W (mm)	W1 (mm)	F (mm)	P (mm)	P1 (mm)	P2 (mm)	A (mm)	B (mm)	t1 (mm)	t2 (mm)
Tolerance	±0.3	±0.15	±0.1	±0.1	±0.1	±0.1	±0.2	±0.2	±0.1	±0.2
Φ6.3x5.7	16	1.75	7.5	12	2	4	7	7	0.4	6.3

■ Parking:

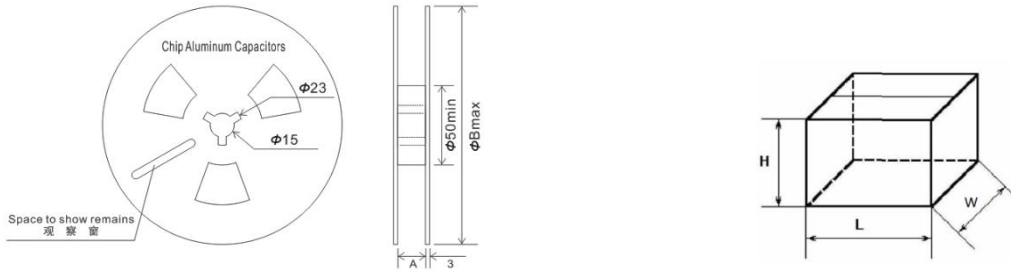

Case	Reel	Box	A±0.3(mm)	B±2(mm)	Box Size (L*W*H)
Φ6.3x5.7	1000	10000	18	382	395*395*235

■ Soldering Conditions:

1. The following conditions are recommended for air convection and infrared reflow soldering on the SMD products onto a glass epoxy circuit boards by cream solder. The temperatures shown are the surface temperature values on the top of the can and on the capacitor terminals.
2. Reflow should be performed twice or less.
3. Please ensure that the capacitor became cold enough to the room temperature (5 to 35 °C) before the second reflow.

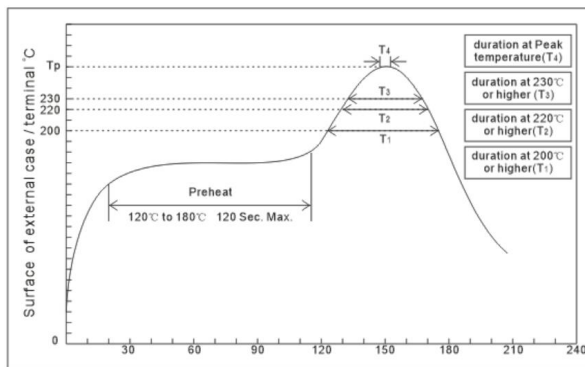

Note:

1. Average ramp-up rate is 5°C/second max.
2. Ramp-down rate is 6°C/second max.
3. Time from 25 °C to peak temperature is 6 minutes max.

Category	Time maintained above 200°C (T1)	Time maintained above 220°C (T2)	Time maintained above 230°C (T3)	Range of Peak		Reflow Number
				Temp.	Times	
Φ6.3	60 sec.	50 sec.	30 sec.	260°C Max.	5sec Max.	2 times or less

4. Recommended Solder Land on PC Board

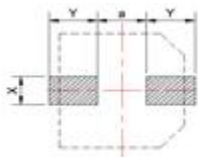

Size	X	Y	a
Φ6.3	1.6	3.5	2.1

Product Characteristics

1. Nominal Capacitance

Test Method	Performance
Measuring Frequency:120Hz Measuring Circuit: Series equivalent circuit. Measuring Voltage: 0.5Vrms or less +1.5 to 2.0 VDC	Refer to Table 1

2. Dissipation Factor

Test Method	Performance
Testing condition are the same as 1.0 for nominal capacitance.	Refer to Table 1

3. Leakage Current

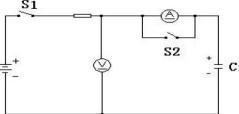
Test Method	Performance
The rated voltage shall be applied across the capacitor and its protective resistor which shall be $1000 \pm 10 \Omega$. The leakage current shall then be measured after an electrification period of 2 min. 	Refer to Table 1

4. Rated Voltage & Surge Voltage

Test Method	Performance
Capacitors shall be applied the surge voltage through a $(100 \pm 50)/CR$ ($K\Omega$) resistor in series for 30 ± 5 seconds in every 5.5 ± 0.5 minutes at $15 \sim 35^\circ C$. Procedure shall be repeated 1000 times. Then the capacitors shall be left under normal humidity for 1~2 hours before measurement. (CR: Nominal Capacitance, μF)	Appearance: Notable changes shall be found. Leakage Current: Not more than the specified value. Capacitance Change: Within $\pm 20\%$ of the initial value. Dissipation Factor: Not more than 175% of the specified value.

Note: This test simulates overvoltage at abnormal situations and not be hypothesizing that overvoltage is always applied.

5. Shelf life test

Test Method	Performance
After $1000+48/-0$ Hrs test at $105 \pm 2^\circ C$ without rated working voltage. And then the capacitor shall be subjected to standard atmospheric conditions for 16 hours, after which measurement shall be made.	Appearance: Notable changes shall be found. Leakage Current: Not more than the specified value. Capacitance Change: Within $\pm 30\%$ of the initial value. Dissipation Factor: Not more than 200% of the specified value.

6. Load life test

Test Method	Performance
Capacitors shall be applied the rated voltage and rated ripple current at $105 \pm 2^\circ C$ for rated life. The Capacitors shall be stored under standard atmospheric conditions for 1~2 hours, after which measurements shall be made.	Appearance: Notable changes shall be found. Leakage Current: Not more than the specified value. Capacitance Change: Within $\pm 30\%$ of the initial value. Dissipation Factor: Not more than 200% of the specified value.

7. Temperature Characteristic

Performance:

Rated voltage (V)	6.3	10	16	25	35	50	63	100
Z(-25°C)/Z(20°C)	4	3	2	2	2	2	2	2
Z(-55°C)/Z(20°C)	8	5	4	3	3	3	3	3

Step 2 3	Impedance Ratio	The value of ratio to Step 1 not more than value of above table.
Step 5	Leakage Current	Not more than 5 time the specified value.
	Capacitance Change	Within $\pm 25\%$ of the value of Step 1.
	Dissipation Factor	Not more than the specified value.

Test Method:

Step	Testing Temperature	Time
1	20 ± 2	Time to reach thermal equilibrium.
2	-25 ± 3	Time to reach thermal equilibrium.
3	-55 ± 3	Time to reach thermal equilibrium.
4	20 ± 2	Time to reach thermal equilibrium.
5	$+105 \pm 3$	Time to reach thermal equilibrium.

Capacitance, Impedance and Dissipation Factor shall be measured at 120Hz.

8. Vibration Test

Test Method	Performance
Testing shall be done out in 3 axis for 2 hours each (Total 6 hours) as below. a).Vibration frequency range: 10~55HZ b).Peak to peak amplitude: 1.5mm c).Sweep rate: 10 to 55 to 10 HZ in about 1 minute.	Appearance: Notable changes shall be found. Capacitance (During test): Measured value shall be stable. (The time from one end to the other of the vibration frequency within last 30 minutes at last direction.) Capacitance Change: Within $\pm 5\%$ of the initial value.

9. Solderability

Test Method	Performance
Terminals of the capacitors shall be immersed into flux (ethanol solution of the rosin, 25wt% rosin) for 5~10 seconds and shall be immersed solder bath ($245\pm 5^{\circ}\text{C}$) to 1.5~2.0mm from the body of the capacitor, and retained for 2 ± 0.5 seconds.	At least 90% of circumferential surface of the dipping portion of termination shall be covered with new solder.

10. Resistance to soldering heat

Test Method	Performance
a. After reflow soldering (Recommended soldering heat conditions). b. The terminal side of the capacitor shall be placed on the heat panel at 250°C for a period of 30 seconds.	Appearance: Notable changes shall be found. Leakage Current: Not more than the specified value. Capacitance Change: Within $\pm 10\%$ of the initial value. Dissipation Factor: Not more than the specified value.

11. Resistance to damp heat

Test Method	Performance
Capacitors shall be stored in the ambient of and $40\pm 5^{\circ}\text{C}$ relative humidity 90~95% for 240 ± 8 hours. Then the capacitors and shall be left under the normal temperature and normal humidity for 1~2 hours before measurement.	Appearance: Notable changes shall be found. Leakage Current: Not more than the specified value. Capacitance Change: Within $\pm 20\%$ of the initial value. Dissipation Factor: Not more than 120% of the specified value.

12. Safety vent

Test Method	Performance
a). AC test The capacitor shall be connected across a applying 50 or 60 Hz AC which is 0.7 times of rated voltage or 250Vrms AC whichever is the lower. b). DC test Applying inverse DC rated voltage with current to the capacitor. Where case diameter: $\phi D \leq 22.4\text{mm}$: 1A DC max. $\phi D > 22.4\text{mm}$: 10A DC max.	When the pressure relief vent operated, the capacitor shall not flame although gas generation or explosion of a part of the inside element is allowable. If the vent does not operate with the voltage applied 30 minutes, the test is considered to be passed. This performance apply to the body of the capacitor with 8mm and larger in diameter.

■ Declaration of Non-use of environment-related Substance

We are hereby to certify the followings:

Our company hereby warrants and guarantees that all of or part of products, including, but not limited to, the peripherals, accessories or package, delivered to your company (including your subsidiaries and affiliated companies) directly or indirectly by our company are free from any of the substances listed below.

- Compliance with the current RoHS Directive 2011/65/EU without any exemption.
- All merchandise and/or material do not contain Substances of Very High Concern (SVHC) are defined in Article XIV of REACH regulation.
- Compliance with Directive 2006/22/EC (PFOA/PFOS)
- Compliance with Directive 2005/84/EC (16P)
- Compliance with ZEK 01.2-08 (PAHs)
- Compliance with SONY SS-00259 V18

■ Important information for application

1. Aluminum electrolytic capacitors are polarized. Make sure of the polarity, if used in reverse polarity, the circuit life may be shortened or the capacitor may be damaged. When the polarity in a circuit sometimes can be reversed or unknown, a bi-polar capacitor shall be used.
2. Do not apply DC voltage, which exceeds the rated voltage of the capacitor and not be reverse voltage. If a voltage exceeding the capacitor's voltage rating is applied, the capacitor may be damaged as leakage current increase. Using capacitors at recommended working voltage prolongs capacitor life. The surge voltage rating is the maximum DC over-voltage to which the capacitors may be subjected of short periods.
3. Use capacitors within rated ripple current. If excessive ripple current is applied on the capacitor, which will result in generating excessive heat inside, reducing capacitance and shortening life of capacitor. The combined value of DC voltage and the peak AC voltage shall not exceed the rated voltage.
4. Use the capacitor according to the specified operating temperature range. If used the capacitor outside the maximum rated temperature will considerably shorten the life or cause the capacitor to vent. Usage at room ambient will ensure longer life. It is generally known that the life doubles for each 10°C decrease in temperature.
5. Leakage current tends to increase when aluminum capacitors have been stored for long period of time. The higher the storage temperature, the higher the leakage current increase. Please take caution when selecting the storage location. The leakage current will decrease gradually as voltage is applied to the capacitor. The capacitor is subjected to aging before using where increased leakage current may cause problems in the circuit.
6. The capacitor is not suitable for a circuit in which charge and discharge are frequently repeated. The capacitance value may drop by forming oxide layer on the cathode foil, or the capacitor may be damaged by generating heat due to continuous rapid charge and discharge.
7. Defective mounting on PCB and improper external strength applied on the lead wires or case body after soldering (see below drawings) may damage inside structure of the capacitor and may cause short circuit, high leakage current or leakage problem.

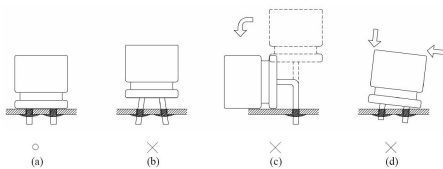

a). Good soldering

b). Hole-to-hole space board differs from the lead space of lead wires. PCB

c). Lead wires are bent after soldering.

d). Case body doesn't stand vertical on board after soldering, Do not bend or twist the capacitor's body after soldering.

8. During soldering process, secondary shrinkage or sleeve crack may occur when soldering temperature is too high or soldering time is too long.
9. The aluminum electrolyte capacitors should be free halogenated solvents during board cleaning after soldering. Use solvent proof capacitors when halogenated solvents are used. After cleaned with the solvent which should proof the quality of capacitors, the capacitors should not be kept in solvent environments of non-ventilated places. Let the capacitors after cleaning dry with hot blast fully above 10mins and the temperature of hot blast should not be over than specified upper limit of capacitors.
10. Do not use halogenated adhesives and coating materials to fix aluminum electrolytic capacitors. Do not cover up all the sealing area of capacitors with adhesives, fixative or coating materials, make coverage only partial.
11. we recommend store with the temperature range between 15 to 35 °C , and the relative humidity of 75% or less , without direct sunshine and store in the package states if possible. Storage time within 12 month after shipment. If storage time more than 12 month, please check the electrical characteristics and solderability before using.
12. Please consult with a local industrial waste disposal specialist when disposing of aluminum electrolytic capacitors.
13. For further details, please refer to EIAJ RCR-2367B (Guideline of notabilia for aluminum electrolytic capacitors for use in electronic equipment).

Table of specification and characteristics

Table 1

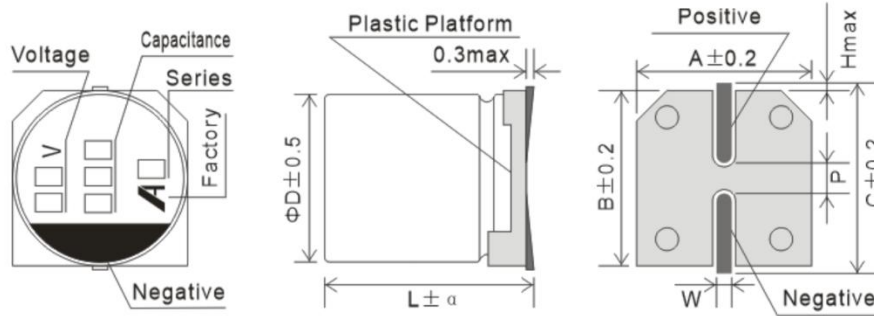

Case	$\Phi 8 \times 10.5$
A	8.3
B	8.3
C	9.0
P	3.1
L	10.5
α	± 0.5
W	0.8~1.1
H	0.5max.

*Marking color: Black

Customer P/N	Series	Rated Capacitance (uF)	Rated Voltage (V)	Case		Capacitance Tolerance (%)	Dissipation factor (% , Max.)	Leakage Current (uA, Max.)	Surge Voltage (V)	Impedance Max. (mΩ, 20°C, 100KHz)	Max. Ripple Current (mA rms) (105°C, 100KHz)	Endurance (Hrs, at 105°C)	Vender P/N
				Diameter (mm)	Height (mm)								
	GVZ	100	35	8	10.5	-20~+20	12.0	35	40.3	160	600	3,000	GVZ1V107M0810CNVC

Explanation of part numbers

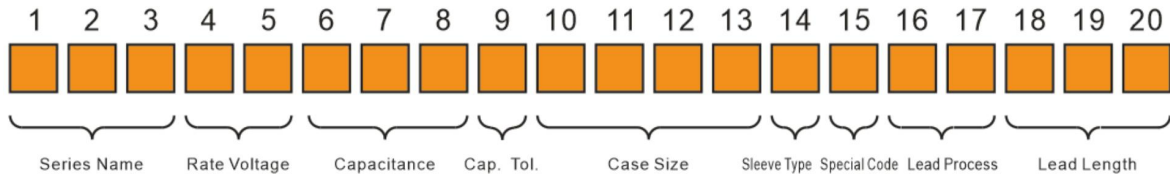

(1-3) 系列	(4-5) 工作电压 (W.V)	代码	(6-8) 静电容量 (μF)	代码	(9) 容差 (%)	代码	(10-13) 产品尺寸 (DxL)	代码	(14) 胶套材质	代码
GVS	4	0G	0.1	104	+5	J	4x5(5.4)	0405	Sleeveless	C
GVT	6.3	0J	0.22	224	-5		4x5.7	0408	PVC	V
GVE	10	1A	0.33	334	+10	K	4x7	0407	PET	E
GVZ	16	1C	0.47	474	-10		5x5(5.4)	0505		
GVM	25	1E	1	105	+15	L	5x5.7	0508		
GVL	35	1V	2.2	225	-15		5x7	0507		
GVJ	50	1H	3.3	335	+20	M	5x11	0511		
GVY	63	1J	4.7	475	-20		6.3x5(5.4)	0605		
GVF	80	1K	10	106	+30	N	6.3x5.7	0608		
GVR	100	2A	22	226	-30		6.3x7	0607		
GVG	125	2B	33	336	+20	V	6.3x7.7	0608		
GVD	160	2C	47	476	-10		6.3x8.7	0609		
GVP	180	2Z	68	686	+30	O	8x6.5	0808		
GVT	200	2D	100	107	-10		8x8	0809		
GVC	220	2P	220	227	+50	T	8x10(10.5)	0810		
GWN	250	2E	330	337	-10		8x11(11.5)	0811		
GVK	315	2F	470	477	+50	S	8x12	0812		
GVA	330	2L	680	687	-20		10x10(10.5)	1010		
	350	2V	1000	108	+80	Z	10x12.5	1012		
	400	2G	2200	228	-20		10x14	1014		
	420	2Q	3300	338	+20	R	12.5x13.5	1213		
	450	2W	4700	478	-0		12.5x16	1216		
	500	2H	6800	688			16x16.5	1616		

(15) 特殊码	代码
无特殊	N
引线直径特殊	D
凸台胶粒	C

(16-17) 引线加工成型	代码	
长脚型	RB	
V-Chip类型品	VC	
Snap-in类型品	SN	
绕性品	ST	
弯脚	直脚弯脚	CC
	成型3.0mm脚距弯脚	FC
	成型2.5mm脚距弯脚	CM
	直脚折曲弯脚	SC
	成型折曲弯脚	FS
	右弯脚	BR
	左弯脚	BL
编带	直脚编带	TS
	成型2.5mm脚距编带	TP
	成型3.0mm脚距编带	TF

(18-20) 剪脚长度	代码
可用剪脚脚长2.8mm	028
可用剪脚脚长3.0mm	030
可用剪脚脚长3.2mm	032
可用剪脚脚长10.0mm	100

■ Conformance Standard

This specification covers "GVZ series" surface mount type aluminum electrolytic capacitors with non-solid electrolyte. This approval sheet consulted the institute of IEC 60384-1 and IEC 60384-4.

■ Operating Temperature Range

Operating temperature range is the range of ambient temperature at which the capacitor can be operated continuously at rated voltage.

Rated Voltage	Temperature
6.3 ~ 100 V _{DC}	-55 ~ +105 °C

■ Condition of test

Unless otherwise specified, the standard range of atmospheric conditions for making measurements and tests are as follows.

Ambient temperature: 15 °C to 35 °C

Relative humidity: 45% to 75%

Air pressure: 86Kpa to 106Kpa

If there may be doubt on the results, measurements shall be made within the following limits.

Ambient temperature: 20 ± 1 °C

Relative humidity: 63% to 67%

Air pressure: 86Kpa to 106Kpa

■ Construction

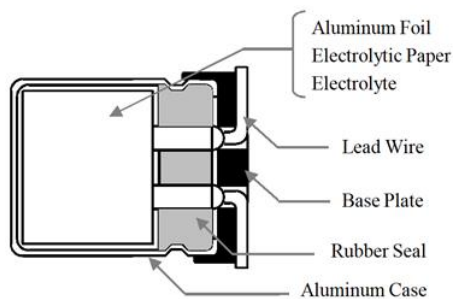

Parts Name	Materials
1 Aluminum Foil	Aluminum
2 Separator Paper	Manila Hemp
3 Electrolyte	Gamma-Butyrolactone
4 Case	Aluminum and PET
5 Rubber Seal	Butyl Rubber
6 Lead Wire	Tinned Copper-Clad Steel Wire
7 Base Plate	Thermo-plastic Resin

■ Ripple Current Frequency Coefficient

Frequency (Hz) \ Capacitance (uF)	50	120	1k	10k	10k up
Under 100	0.35	0.50	0.70	0.90	1.00
100 ~ 2200uF	0.40	0.65	0.85	0.95	1.00

※The endurance of capacitors is reduced with internal heating produced by ripple current at the rate of halving the lifetime with every 5 °C rise. When long life performance is required in actual use, the rms ripple current has to be reduced.

■ Taping Specifications:

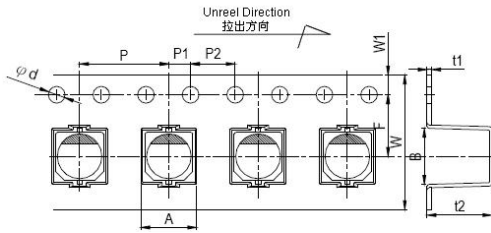

Case	W (mm)	W1 (mm)	F (mm)	P (mm)	P1 (mm)	P2 (mm)	A (mm)	B (mm)	t1 (mm)	t2 (mm)
Tolerance	±0.3	±0.15	±0.1	±0.1	±0.1	±0.1	±0.2	±0.2	±0.1	±0.2
φ8x10.5	24	1.75	11.5	16	2	4	8.7	8.7	0.4	11

■ Parking:

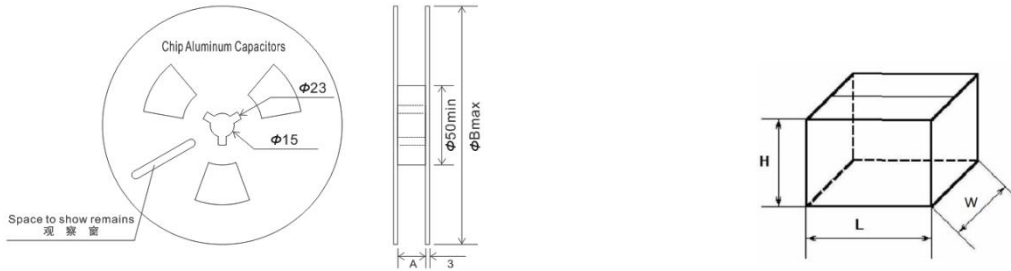

Case	Reel	Box	A±0.3(mm)	B±2(mm)	Box Size (L*W*H)
φ8x10.5	500	5000	26	382	395*395*315

■ Soldering Conditions:

1. The following conditions are recommended for air convection and infrared reflow soldering on the SMD products onto a glass epoxy circuit boards by cream solder. The temperatures shown are the surface temperature values on the top of the can and on the capacitor terminals.
2. Reflow should be performed twice or less.
3. Please ensure that the capacitor became cold enough to the room temperature (5 to 35 °C) before the second reflow.

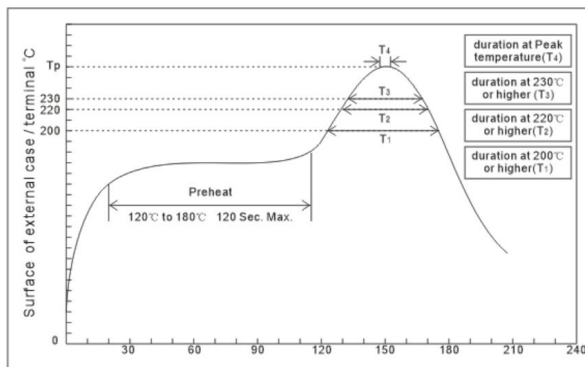

Note:

1. Average ramp-up rate is 5°C/second max.
2. Ramp-down rate is 6°C/second max.
3. Time from 25 °C to peak temperature is 6 minutes max.

Category	Time maintained above 200°C (T1)	Time maintained above 220°C (T2)	Time maintained above 230°C (T3)	Range of Peak		Reflow Number
				Temp.	Times	
φ8	60 sec.	50 sec.	30 sec.	255°C Max.	5sec Max.	2 times or less

4. Recommended Solder Land on PC Board

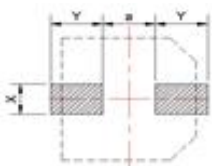

Size	X	Y	a
φ8	2.5	3.5	3.0

Product Characteristics

1. Nominal Capacitance

Test Method	Performance
Measuring Frequency:120Hz Measuring Circuit: Series equivalent circuit. Measuring Voltage: 0.5Vrms or less +1.5 to 2.0 VDC	Refer to Table 1

2. Dissipation Factor

Test Method	Performance
Testing condition are the same as 1.0 for nominal capacitance.	Refer to Table 1

3. Leakage Current

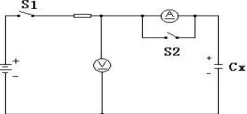
Test Method	Performance
The rated voltage shall be applied across the capacitor and its protective resistor which shall be $1000 \pm 10 \Omega$. The leakage current shall then be measured after an electrification period of 2 min. 	Refer to Table 1

4. Rated Voltage & Surge Voltage

Test Method	Performance
Capacitors shall be applied the surge voltage through a $(100 \pm 50)/CR$ (K Ω) resistor in series for 30 ± 5 seconds in every 5.5 ± 0.5 minutes at $15 \sim 35^\circ C$. Procedure shall be repeated 1000 times. Then the capacitors shall be left under normal humidity for 1~2 hours before measurement. (CR: Nominal Capacitance, μF)	Appearance: Notable changes shall be found. Leakage Current: Not more than the specified value. Capacitance Change: Within $\pm 20\%$ of the initial value. Dissipation Factor: Not more than 175% of the specified value.

Note: This test simulates overvoltage at abnormal situations and not be hypothesizing that overvoltage is always applied.

5. Shelf life test

Test Method	Performance
After $1000+48/-0$ Hrs test at $105 \pm 2^\circ C$ without rated working voltage. And then the capacitor shall be subjected to standard atmospheric conditions for 16 hours, after which measurement shall be made.	Appearance: Notable changes shall be found. Leakage Current: Not more than the specified value. Capacitance Change: Within $\pm 30\%$ of the initial value. Dissipation Factor: Not more than 200% of the specified value.

6. Load life test

Test Method	Performance
Capacitors shall be applied the rated voltage and rated ripple current at $105 \pm 2^\circ C$ for rated life. The Capacitors shall be stored under standard atmospheric conditions for 1~2 hours, after which measurements shall be made.	Appearance: Notable changes shall be found. Leakage Current: Not more than the specified value. Capacitance Change: Within $\pm 30\%$ of the initial value. Dissipation Factor: Not more than 200% of the specified value.

7. Temperature Characteristic

Performance:

Rated voltage (V)	6.3	10	16	25	35	50	63	100
Z(-25 $^\circ C$)/Z(20 $^\circ C$)	4	3	2	2	2	2	2	2
Z(-55 $^\circ C$)/Z(20 $^\circ C$)	8	5	4	3	3	3	3	3

Step 2 3	Impedance Ratio	The value of ratio to Step 1 not more than value of above table.
Step 5	Leakage Current	Not more than 5 time the specified value.
	Capacitance Change	Within $\pm 25\%$ of the value of Step 1.
	Dissipation Factor	Not more than the specified value.

Test Method:

Step	Testing Temperature	Time
1	20 ± 2	Time to reach thermal equilibrium.
2	-25 ± 3	Time to reach thermal equilibrium.
3	-55 ± 3	Time to reach thermal equilibrium.
4	20 ± 2	Time to reach thermal equilibrium.
5	$+105 \pm 3$	Time to reach thermal equilibrium.

Capacitance, Impedance and Dissipation Factor shall be measured at 120Hz.

8. Vibration Test

Test Method	Performance
Testing shall be done out in 3 axis for 2 hours each (Total 6 hours) as below. a).Vibration frequency range: 10~55HZ b).Peak to peak amplitude: 1.5mm c).Sweep rate: 10 to 55 to 10 HZ in about 1 minute.	Appearance: Notable changes shall be found. Capacitance (During test): Measured value shall be stable. (The time from one end to the other of the vibration frequency within last 30 minutes at last direction.) Capacitance Change: Within $\pm 5\%$ of the initial value.

9. Solderability

Test Method	Performance
Terminals of the capacitors shall be immersed into flux (ethanol solution of the rosin, 25wt% rosin) for 5~10 seconds and shall be immersed solder bath ($245\pm 5^{\circ}\text{C}$) to 1.5~2.0mm from the body of the capacitor, and retained for 2 ± 0.5 seconds.	At least 90% of circumferential surface of the dipping portion of termination shall be covered with new solder.

10. Resistance to soldering heat

Test Method	Performance
a. After reflow soldering (Recommended soldering heat conditions). b. The terminal side of the capacitor shall be placed on the heat panel at 250°C for a period of 30 seconds.	Appearance: Notable changes shall be found. Leakage Current: Not more than the specified value. Capacitance Change: Within $\pm 10\%$ of the initial value. Dissipation Factor: Not more than the specified value.

11. Resistance to damp heat

Test Method	Performance
Capacitors shall be stored in the ambient of and $40\pm 5^{\circ}\text{C}$ relative humidity 90~95% for 240 ± 8 hours. Then the capacitors and shall be left under the normal temperature and normal humidity for 1~2 hours before measurement.	Appearance: Notable changes shall be found. Leakage Current: Not more than the specified value. Capacitance Change: Within $\pm 20\%$ of the initial value. Dissipation Factor: Not more than 120% of the specified value.

12. Safety vent

Test Method	Performance
a). AC test The capacitor shall be connected across a applying 50 or 60 Hz AC which is 0.7 times of rated voltage or 250Vrms AC whichever is the lower. b). DC test Applying inverse DC rated voltage with current to the capacitor. Where case diameter: $\phi D \leq 22.4\text{mm}$: 1A DC max. $\phi D > 22.4\text{mm}$: 10A DC max.	When the pressure relief vent operated, the capacitor shall not flame although gas generation or explosion of a part of the inside element is allowable. If the vent does not operate with the voltage applied 30 minutes, the test is considered to be passed. This performance apply to the body of the capacitor with 8mm and larger in diameter.

■ Declaration of Non-use of environment-related Substance

We are hereby to certify the followings:

Our company hereby warrants and guarantees that all of or part of products, including, but not limited to, the peripherals, accessories or package, delivered to your company (including your subsidiaries and affiliated companies) directly or indirectly by our company are free from any of the substances listed below.

- Compliance with the current RoHS Directive 2011/65/EU without any exemption.
- All merchandise and/or material do not contain Substances of Very High Concern (SVHC) are defined in Article XIV of REACH regulation.
- Compliance with Directive 2006/22/EC (PFOA/PFOS)
- Compliance with Directive 2005/84/EC (16P)
- Compliance with ZEK 01.2-08 (PAHs)
- Compliance with SONY SS-00259 V18

■ Important information for application

1. Aluminum electrolytic capacitors are polarized. Make sure of the polarity, if used in reverse polarity, the circuit life may be shortened or the capacitor may be damaged. When the polarity in a circuit sometimes can be reversed or unknown, a bi-polar capacitor shall be used.
2. Do not apply DC voltage, which exceeds the rated voltage of the capacitor and not be reverse voltage. If a voltage exceeding the capacitor's voltage rating is applied, the capacitor may be damaged as leakage current increase. Using capacitors at recommended working voltage prolongs capacitor life. The surge voltage rating is the maximum DC over-voltage to which the capacitors may be subjected of short periods.
3. Use capacitors within rated ripple current. If excessive ripple current is applied on the capacitor, which will result in generating excessive heat inside, reducing capacitance and shortening life of capacitor. The combined value of DC voltage and the peak AC voltage shall not exceed the rated voltage.
4. Use the capacitor according to the specified operating temperature range. If used the capacitor outside the maximum rated temperature will considerably shorten the life or cause the capacitor to vent. Usage at room ambient will ensure longer life. It is generally known that the life doubles for each 10°C decrease in temperature.
5. Leakage current tends to increase when aluminum capacitors have been stored for long period of time. The higher the storage temperature, the higher the leakage current increase. Please take caution when selecting the storage location. The leakage current will decrease gradually as voltage is applied to the capacitor. The capacitor is subjected to aging before using where increased leakage current may cause problems in the circuit.
6. The capacitor is not suitable for a circuit in which charge and discharge are frequently repeated. The capacitance value may drop by forming oxide layer on the cathode foil, or the capacitor may be damaged by generating heat due to continuous rapid charge and discharge.
7. Defective mounting on PCB and improper external strength applied on the lead wires or case body after soldering (see below drawings) may damage inside structure of the capacitor and may cause short circuit, high leakage current or leakage problem.

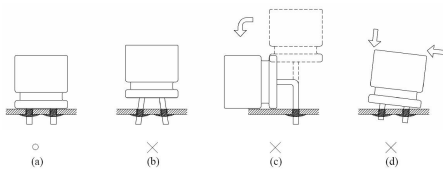

a). Good soldering

b). Hole-to-hole space board differs from the lead space of lead wires. PCB

c). Lead wires are bent after soldering.

d). Case body doesn't stand vertical on board after soldering, Do not bend or twist the capacitor's body after soldering.

8. During soldering process, secondary shrinkage or sleeve crack may occur when soldering temperature is too high or soldering time is too long.
9. The aluminum electrolyte capacitors should be free halogenated solvents during board cleaning after soldering. Use solvent proof capacitors when halogenated solvents are used. After cleaned with the solvent which should proof the quality of capacitors, the capacitors should not be kept in solvent environments of non-ventilated places. Let the capacitors after cleaning dry with hot blast fully above 10mins and the temperature of hot blast should not be over than specified upper limit of capacitors.
10. Do not use halogenated adhesives and coating materials to fix aluminum electrolytic capacitors. Do not cover up all the sealing area of capacitors with adhesives, fixative or coating materials, make coverage only partial.
11. we recommend store with the temperature range between 15 to 35 °C , and the relative humidity of 75% or less , without direct sunshine and store in the package states if possible. Storage time within 12 month after shipment. If storage time more than 12 month, please check the electrical characteristics and solderability before using.
12. Please consult with a local industrial waste disposal specialist when disposing of aluminum electrolytic capacitors.
13. For further details, please refer to EIAJ RCR-2367B (Guideline of notabilia for aluminum electrolytic capacitors for use in electronic equipment).